



Camseal[®] Ball Valve Servicing Instructions



I INSTALLATION

Perform installation welding in accordance with ASME Boiler and Pressure Vessel Code, Sec. 1, Part PW, or ANSI B 3.1.1, Para 127. Camseal Valves are uni-directional and care should be taken to weld in line with flow in the direction of the arrow on the body of the valve.

- A. Do not disassemble valve. Valve should be placed in the “full open” position during welding.
- B. Allow 1/16” gap between bottom of socket weld end and the end of the pipe (PW 41.5.7, or ANSI B 3.1.1, Para 127.3).
- C. Preheat per and PWHT per Table I.
- D. PWHT as shown in PWHT Guidelines

MATERIAL	Material thickness	P No.	Group	Preheat	** Holding Temp	** Holding time based on Nonimal Thickness	
						Up to 2 inches	Over 2 inches
A-105	<1"	1	1,2,3,	50°F	1,100-1,200°F	1 hr/in. 15 min min	2 hrs plus 15 minutes for each additional inch over 2 inches
A-105	>1"	1	1,2,3,	200°F	1,100-1,200°F		
F22	>5/8"	5A	1	400°F	1,250-1,400°F	1 hr per inch	
F91/F91S	All	15E	1	400°F	1,300-1,425°F	1 hour per inch 30 minutes minimum	1 hour per inch up to 5 inch plus 15 minutes for each additional inch over 5 inch minimum
F316/F316H	All	8	1 or 3	60°F	NR	NR	NR
F347/F347H	All	8	1 or 3	60°F	NR	NR	NR

*ASME BOILER AND PRESSURE VESSEL CODE, SECTION I, PART PW-38, PWHT REQUIREMENTS PER ASME BOILER AND PRESSURE VESSEL CODE AND ASME B31.1 AND ASME B31.3

** - For exceptions to mandatory PWHT refer to the relevant code.

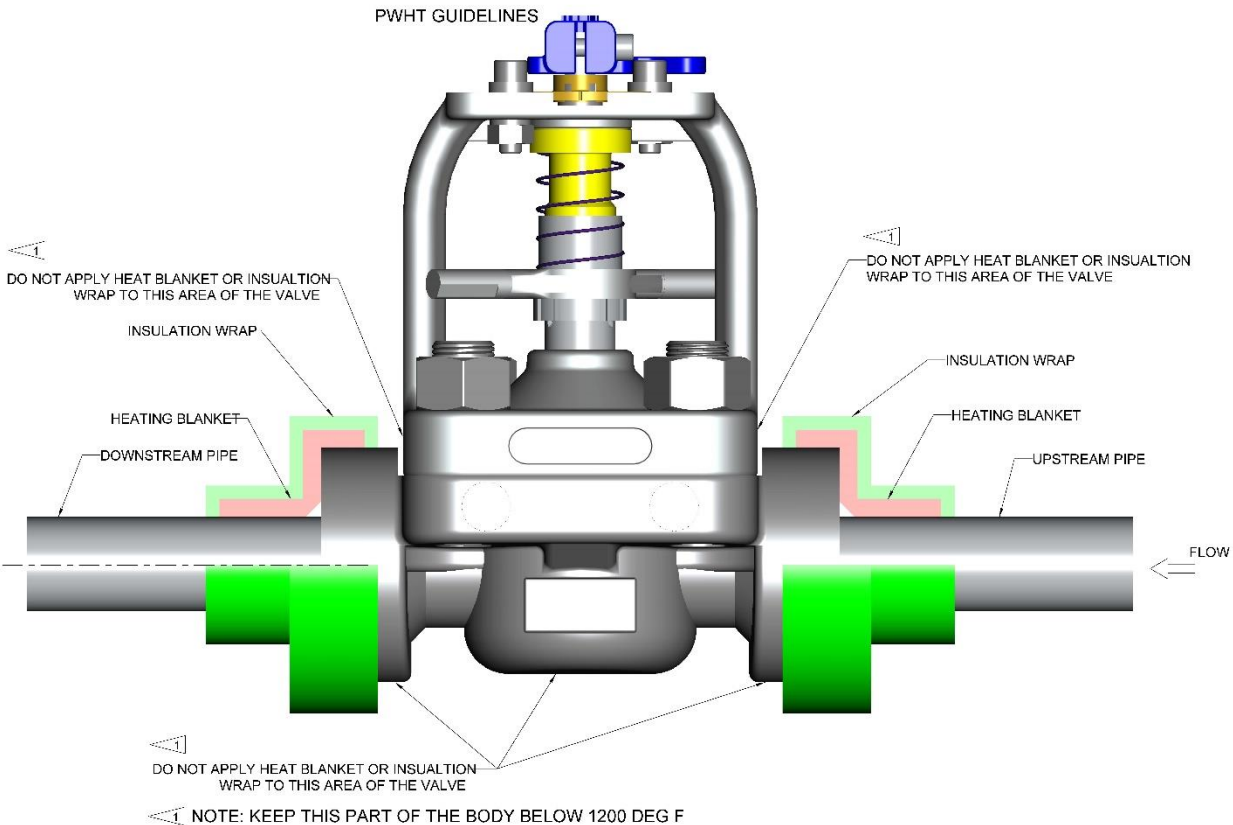

III

PACKING GLAND ADJUSTMENT

Camseal ball valves have a precision packing system with a single piece splined gland. Packing may need to be adjusted periodically to prevent leakage.

Camseal ball valves are furnished with an Integral Gland Wrench (IGW). The IGW provides for easy packing maintenance which helps extend packing life. To tighten the packing be sure the teeth of the IGW are engaged with the teeth in the gland and turn the IGW clockwise until you have the specified torque (see Figure 2 for gland torques) or until the leak stops. Once the packing has been properly adjusted, lift the IGW and rotate it back counter-clockwise until the IGW is locked against the arms of the yoke. This will prevent the gland from backing off and allowing leakage to develop.

IV

VALVE REBUILDING

CAUTION: Before any attempt is made to disassemble the valve, verify that the valve is isolated from system pressure and secured against accidental pressurization. Follow all of the plant standard tag out safety procedures before proceeding.

The Camseal ball valve contains a cartridge assembly that allows the entire valve to be rebuilt by changing out the old cartridge assembly for a new one. All parts necessary to do this are included in a Camseal repair kit (repair kit includes: cartridge assembly, body to seat laminate seal, and body/bonnet laminate seal. It is not necessary to disassemble the cartridge and rebuild any of the internal components, nor is it recommended. Refer to Figures 1A thru 1C for diagrams with more detail on the steps described below.

1. Remove the yoke and bonnet from the valve by rotating the nuts that are threaded onto the studs that secure the yoke to the valve body. Remove the nuts by rotating counterclockwise (the #5 valve has 4 nuts, the #7 valve has 6 nuts, the #9 valve has 8 nuts, and #10 has 12 nuts.). If a nut has become locked to the stud and the stud and nut come out as a unit, this is acceptable. Simply remove and re- install as an assembly. When all of the nuts are removed, lift the yoke straight up and off of the valve body. The bonnet will come off separately with the stem, gland, bushing, IGW and IGW spring.
2. Remove the cam retainer clip (spring) - if so equipped – and discard as it will not be replaced. Using a long socket wrench (sizes shown in Figure 3) rotate the 2 cams until the flat of the cam is resting on the cartridge spacer and has relaxed compression on the Belleville washer (the cam pins should be rotated in the direction that will allow the cartridge to be relaxed with just 90 degree turn). The cam on the right side of the cartridge (when looking downstream) will be turned 90° clockwise, the cam on the left side of the cartridge will be turned 90° counterclockwise.
3. Remove the cams.
4. Remove the cartridge by sliding it up and out from the body of the valve. The cartridge seal, Bellville washer and spacer will also come out as part of this sub- assembly.
5. Clean and inspect all sealing surfaces of the valve assembly: the bonnet seal surface, the mating seal surface in the body and the sealing surface that mates with the cartridge seal. Use Scotchbrite or a similar material to remove rust and dirt that may prevent the new cartridge seal from sealing. For valves which have a laminate seal, it may be necessary to remove any remnants of the seal which have bonded to the surfaces using a plastic knife or scraper. Examine all surfaces and make certain there is no corrosion or damage in the sealing surfaces. Once this has been done, take precautions to assure these critical surfaces are not damaged during handling and re-assembly. If the body/bonnet seal area has too much wear to be cleaned up with Scotch-Brite, follow the special instructions for using the Camseal Body/ Bonnet Seal Refacing Tool (See Section VIII at the end of this document). Valves that have C-seals will be replaced with laminate seals which require a rougher finish per the instructions of Section VIII.
6. The new cartridge needs to be sub-assembled with new mating components. Place the new cartridge seal in the seal groove of the new cartridge. Place the spacer onto the cartridge. Place the Belleville washer against the spacer, making certain the Belleville washer is installed with the small (convex) diameter facing away from the spacer. (9J has 2 bellevilles in series)
7. Insert the new cartridge assembly into the body, carefully sliding it between the milled locating ribs on the inside of the valve body. The valve is designed so that the cartridge is automatically oriented correctly; it will only go into the valve one way. Make certain the cartridge seal remains in place and is not scraped or damaged during insertion of the cartridge into the body. Also make certain the cartridge slides all the way to the bottom of the internal cavity.

8. Slide the cams back into place. The cams must be oriented with the flat facing toward the spacer; this is the only orientation in which the cams will freely slide into position.
9. Rotate the cams 90 degrees to compress the Belleville washer and load the cartridge seal; for an optimum seal use two socket wrenches and rotate both cams simultaneously (for best results rotate the cam-pins so that the flat side faces the side wall of the valve). The cam on the right side of the cartridge (when looking downstream) will be turned 90° counterclockwise, the cam on the left side of the cartridge will be turned 90° clockwise. When in the correct position the witness mark on the cams will be in line with the pipe line.

V REPACKING

1. Remove the handle from the valve by loosening the handle retaining screw and then lift off the handle.
2. Remove the stem from the bonnet by rotating the Integral gland wrench (IGW) counterclockwise to remove the pressure on the packing and continue turning until there is a gap between the packing chamber and the bottom of the gland (exposing a portion of the stem). Remove the snap ring (if so equipped) from the top of the stem, the snap ring will be replaced with a Position Indicator Disc, tap the stem downward through the yoke and bonnet. Valves that have an indicating disc, the disc will pop off the stem when the stem is tapped downward thru the bonnet.
3. Once the stem has been removed from the yoke and bonnet, the bonnet will be separated from the yoke/bushing/gland assembly.
The gland must be loosened, or turned all the way back up on the bushing counterclockwise for reassembly. Once the gland has been turned all the way back up onto the bushing, the gland/bushing assembly will be ready for reassembly. Deleted line about gland and bushing getting stuck and needing to be tapped out.
4. Remove the packing assembly using a hook of brass or a similar soft material that will not score the packing bore. First pull out the packing spacer that sits on top of the packing, and then remove all 5 of the individual packing rings, taking care not to damage the packing bore.
5. Clean the bonnet (packing) chamber with cleaning solvent to remove contaminants and polish with Scotchbrite or a similar material.
6. Polish the stem with Scotchbrite or a similar material making sure to remove any remnants of the old packing, dirt or corrosion.
7. To repack the bonnet, turn the stem upside down and slide it down through the packing set into the top of the bonnet. The stem does not normally go in this way, it can be used to guide the insertion of the packing.

- 8.** The packing is pre-packaged in plastic wrap. This plastic needs to remain in place until the packing is installed in the packing bore. Place the packing assembly up onto the stem and push the stem down through the packing bore. It will protrude out the bottom of the bonnet. Use the stem to pull the packing into place. As the packing slides into the bore, the plastic wrap will peel off and will need to be removed. It may be necessary to tap the stem with a rubber mallet to completely seat the packing in the packing bore. Once the packing is in place, remove the stem and repeat this process to install the packing spacer. Make certain that the packing spacer is at least partially inserted into the packing chamber.
- 9.** Insert the bushing/gland assembly up into the yoke making certain the flats on the top of the bushing mate up with the ribs built into the mating surface of the yoke to prevent the bushing from rotating. Removed expansion pin note
Rotate the packing gland to mid stroke so that the stem will not work to push the packing out of the packing bore.
- 10.** Holding the bushing/gland in place, insert the stem from the bottom of the bonnet and slide it up through the gland and bushing until it protrudes up through the top of the yoke. Make certain the collar of the stem is fully seated against the thrust bearing in the bottom of the bonnet.
- 11.** Reinstall the Position Indicator Disk into the groove on the top of the stem to retain the stem. Slide the indicator disk slot over the top of the stem and tap into place using a small mallet and a socket just slightly larger than the end of the stem until the Position Indicator Disk snaps into the ring groove.
- 12.** Compress the packing by rotating the IGW clockwise. Note that this may require several turns since the gland is at mid travel to prevent the packing spacer from coming out. Rotate the IGW until you achieve the proper gland torque (see Figure 2).

VI **REASSEMBLY**

1. Clean the bonnet seal sealing surfaces of both the body and the bonnet with Scotchbrite or similar cloth to remove any dirt or imperfections. For valves which have a laminate seal, it may be necessary to remove any remnants of the seal which may have bonded to the surfaces using a plastic knife or scraper. Examine these surfaces and make certain there is no damage that could affect the sealing of the valve. Place the new seal ring in the seal groove in the body.
2. Position the stem in the closed position, with the upper stem flats perpendicular to the pipe line. (This will assure that the stem will line up with the ball slot, as the ball is assembled in the closed position in the cartridge by the factory.) Place the yoke/bonnet assembly (yoke/bonnet, stem, gland) onto the body making certain that the stem properly engages the ball slot and that the centering ring (some actuated valves do not have a centering ring, skip this step if no centering ring is supplied) on the yoke is aligned with the body.
3. Lubricate the studs and nuts with Never-Seez or a similar high temperature anti-galling lubricant. Replace the nuts and tighten them by hand to snug the yoke down in place. Gradually tighten the nuts one nut at a time following a diagonal pattern. Tighten the nuts to the torque values shown in Figure 4 (always be sure at least one thread is showing above every nut when they are tight).
4. If so equipped, replace the handle on the stem and tighten the handle retaining screw.

VII **ACTUATOR SIZING AND MOUNTING INSTRUCTIONS**

General Actuator Mounting Notes

1. Please consult the factory when sizing actuators. Pressures and temperatures influence the actuator sizing and stand-off height required. Figure 5 shows the torque requirements for the various Camseal size codes.
2. If you have purchased a Conval ball valve as a manual valve and plan on automating the valve, please make note of the torque guidelines in Figure 5A,B when sizing the actuator.
3. Only quarter turn actuators may be used with the Camseal ball valve.
4. Take care when mounting the actuator to the ball valve. Some applications require high torques and large actuators. In applications below 150 F, the actuator can be direct mounted. If a mounting bracket is required be certain that the mounting bracket is sufficient to support the weight of the actuator and remain rigid, stable and properly aligned under all operating conditions.
5. Be sure there is a slight vertical gap of approximately 0.050" to 0.060" between the actuator coupling and the actuator shaft. This gap will compensate for tolerances of the assembly and also allow slight movement due to thermal growth of individual components.

6. Alignment between the actuator, the stand-off, coupling and the valve is critical. Any off-center loading can create considerably higher torques on the valve and cause premature wear of the internal components of the valve.
7. Set the actuator stops so that the actuator travels to both the fully open and fully closed positions, using the Position Indicator Disc. The setting of the actuator stops is very important. The actuator stops will provide the only rotation limits of the valve assembly, so it is critical that the actuator be set to provide a full and proper 0 and 90 degree positioning of the ball. This will require slight over-travel of the actuator at each end of travel, resulting in total actuator travel slightly more than 90 degrees.

Mounting Procedure

CAUTION: If removing an actuator which has been mounted at the factory for any reason, it is recommended that the precise position of the actuator-to-bracket and bracket-to-yoke location be **MATCH MARKED** to ensure the correct position of the stem and ball upon reassembly. **IF NOT**, the actuator will have to be **CYCLED** and the correct **CLOSED** and **OPEN** position of the stem (See Figure 1A) must be verified by adjustment of the actuator stops to correctly line up with the Position Indicator and the yoke scribe lines.

1. Remove the external position stops from the yoke of the manual valve by unscrewing them from the top of the yoke assembly.
2. Before mounting the operator to the valve, be certain the valve is in the closed position verify by using the Position Indicator Disc as shown in Figure 1A.
3. If direct mounting the actuator, insert the actuator coupling onto the end of the stem. The bottom of the coupling should be flush with the top of the valve stem. Tighten the set screw until it makes contact with the flat on the double D or square of the stem. In general – when the valve is open – the flats of the double-D end of the stem will be parallel with the pipeline axis, stems with a single keyway will be perpendicular to the pipeline axis, and stems with a square drive will have a mark perpendicular to the pipe axis. **HOWEVER**, to be the most accurate and ensure shutoff – it is always recommended to match up the stem valve-closed markings using the Indicator Disk as depicted in Figure 1A.
Note: When direct-mounting actuators on valves supplied with the indicator disk, it may be necessary to use a spacer plate for older bonnet designs where the indicator protrudes slightly above the top surface.
4. If the valve/actuator combination requires a stand-off, place the stand-off on the valve mounting flange. Orient the stand-off to align properly with the bolt circle of the valve flange. Bolt the two components together. Insert the coupler as in step 3 above.
5. Place the actuator on the valve (direct mount) or on the top of the bracket, making sure that the actuator is oriented in the closed position.

- 6.** The coupling should engage the mating shaft of the actuator, leaving a 0.050 to 0.060 inch gap between the top of the coupling and the bottom of the mating shaft. This gap is essential to ensure proper assembly and operation of the valve/actuator unit.
- 7.** Bolt the actuator to the valve or stand-off making sure that the axes of the actuator output shaft and the coupler are very accurately aligned with the axes of the ball valve stem. Failure to properly align the assembly will result in valve stem leakage, potential damage to other portions of the valve assembly, and possible system shut down.
- 8.** Verify that the actuator stops have been set so that the valve is operated to the fully open and fully closed positions verify using the Position Indicator Disc.
- 9.** Actuators can be direct mounted to the ISO pattern on the mounting pad of the Camseal for process temperatures up to 150 F, with the use of a spacer plate as discussed in section 3. Stand-offs are required on process temperatures over 150 F to assure that the actuator is not damaged by excessive heat from the pipe line. Stand-off heights should be a minimum of 6 inches for the number 5 Camseal, and 4 inches for the number 7 and 9 valves.

Figure 1 A Valve Assembly

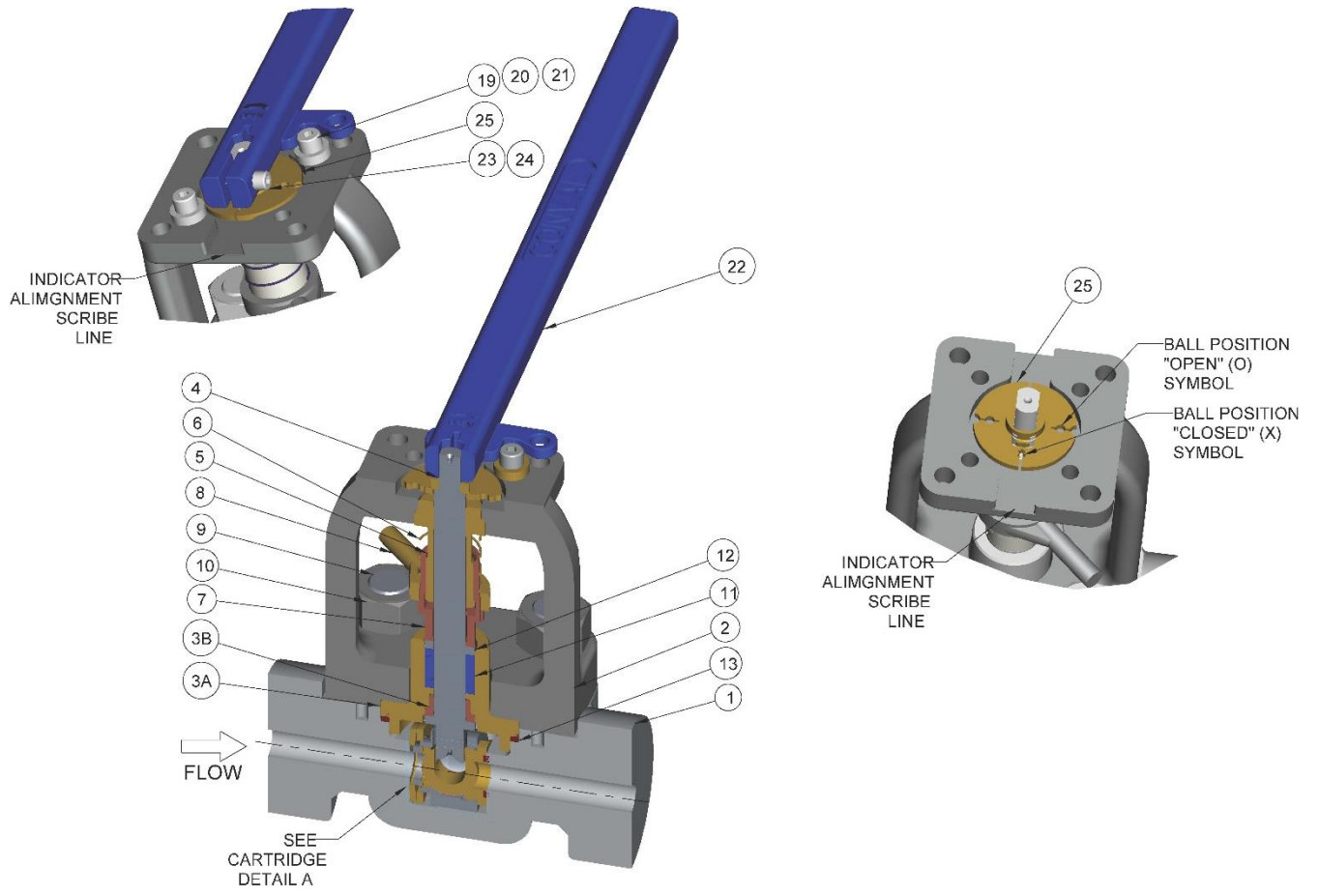

Figure 1B

LIST OF MATERIALS FOR 1700# AND 3100# VALVES						
NO.	NAME	QTY	MATERIALS			
1	BODY	1	ASME SA-105	ASME SA-182 F22	ASME SA-182 F91	ASME SA-182 F316
2	YOKE	1	ASME SA-105	ASME SA-182 F22	ASME SA-182 F91	ASME SA-182 F316
3	BONNET ASSEMBLY	1	SEE MATERIALS BELOW			
3A	BONNET	1	ASME SA-216 Gr WCB	ASME SA-217 Gr WC9	ASME SA-217 Gr C12A	ASME SA-351 Gr CF3M
3B	BONNET STEM BEARING****	1	ASME SA-479 TYPE 410	ASME SA-479 TYPE 410	ASME SA-479 TYPE 410	AMS 5387 STELLITE #6
4	STEM**	1	ASTM A582 TYPE 416	ASME SB637 UNS N07718	ASME SB637 UNS N07718	ASME SB637 UNS N07718
5	BUSHING	1	ASME SB150 ALUMINUM BRONZE			
6	IGW SPRING	1	MFR STANDARD STAINLESS			
7	GLAND	1	ASTM A582 TYPE 416	ASTM A582 TYPE 416	ASTM A582 TYPE 416	ASME SA-479 TYPE 316
8	INTEGRAL GLAND WRENCH (IGW)	1	MFR STANDARD STAINLESS			
9	BODY STUD*	SD	ASME SA193 Gr B16	ASME SA193 Gr B16	ASME SA193 Gr B16	ASME SA193 Gr B8M
10	BODY FLANGE NUT*	SD	ASME SA194 Gr 4	ASME SA194 Gr 4	ASME SA194 Gr 4	ASME SA194 Gr 8M
11	PACKING SET	1	BRAIDED & DIE-MOLDED FLEXIBLE GRAPHITE			
12	PACKING SPACER	1	ASME SA-479 UNS S21800 (NITRONIC 60)			
13	BODY/BONNET SEAL	1	316 SST/FLEXIBLE GRAPHITE LAMINATE			
14	CARTRIDGE ASSEMBLY	1	SEE MATERIALS BELOW			
14A	CARTRIDGE	1	ASME SA-479 TYPE 410	ASME SA-479 TYPE 410	ASME SA-479 TYPE 410	ASME SA-479 TYPE 316
14B	COATED SEAT	1	ASME SB637 UNS N07718 / CHROME CARBIDE			
14C	COATED BALL	1	ASME SB637 UNS N07718 / CHROME CARBIDE			
14D	UPSTREAM SEAT	1	ASME SA-479 TYPE 410	ASME SA-479 TYPE 410	ASME SA-479 TYPE 410	AMS 5387 STELLITE #6
14E	UPSTREAM SEAT BELLEVILLE	1	ASME SB637 UNS N07718			
15	SEAT/BODY SEAL	1	316 SST/FLEXIBLE GRAPHITE LAMINATE			
16	CAM	1	ASME SA-479 TYPE 410	ASME SA-479 TYPE 410	ASME SA-479 TYPE 410	ASME SA-479 UNS S20910
17	SPACER	1	ASME SB637 UNS N07718			
18	CAM BELLEVILLE	1	ASME SB637 UNS N07718			
19	STOP BOLT*	1	MFR STANDARD STAINLESS			
20	STOP NUT*	1	MFR STANDARD STAINLESS			
21	STOP LOCK WASHER*	1	MFR STANDARD STAINLESS			
22	HANDLE*	1	ASME SA-216 Gr WCB			
23	HANDLE NUT*	1	MFR STANDARD CARBON STEEL			
24	HANDLE BOLT*	1	MFR STANDARD ALLOY STEEL			
25	POSITION INDICATOR DISK	1	ANODIZED ALUMINUM ALLOY T6061			
NOTES:						
* SD = SIZE DEPENDENT						
** FOR 4500#, STEM IS ASME SB637 UNS N07718 (INCONEL 718)						
*** FOR 4500#, BODY/BONNET SEAL IS ASTM B670 PLATED						
*** FOR 4500#, STEM BUSHING IS AMS 5387 STELLITE #6.						

Figure 1 C
Detail of Cartridge and Cam Assembly

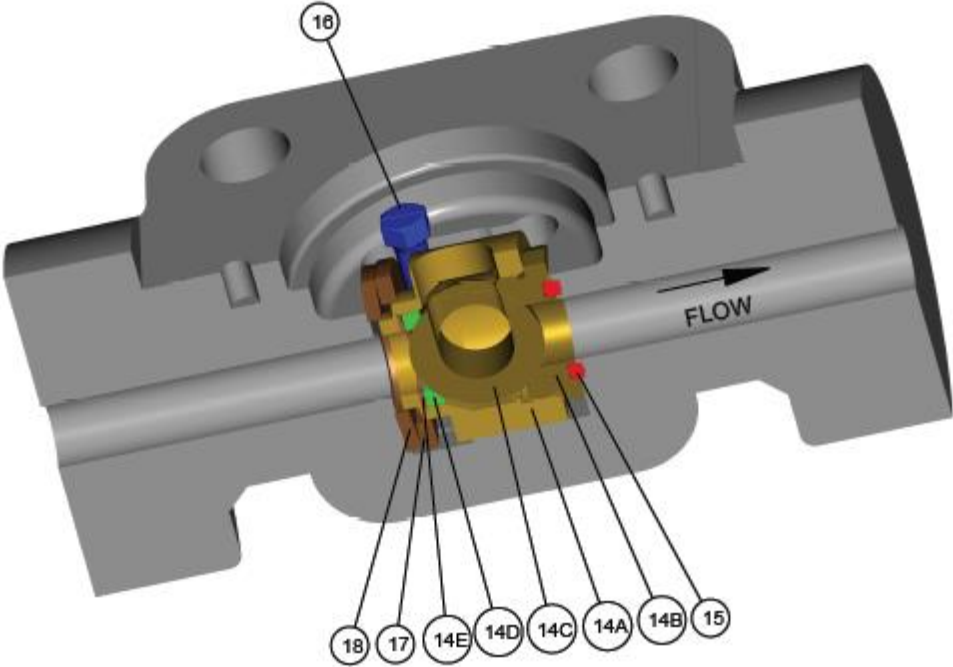

Figure 2

	REQUIRED TORQUE (FT-LBS)
VALVE SIZE CODE	GLAND
5E	37
7E	37
7H	47
9H	47
9J	180
9K	180
10N	340

Figure 3

CAM SOCKET WRENCH REQUIREMENTS	
VALVE SIZE CODE	CAM HEX DIMENSION
5E	3/8"
7E	3/8"
7H	7/16"
9H	7/16"
9J	7/16"
9K	7/16"
10N	9/16"

Figure 4

	REQUIRED TORQUE (FT-LBS)
VALVE SIZE CODE	BONNET NUT
5E	330
7E	500
7H	500
9H	500
9J	500
9K	500
10N	500

Figure 5A - Camseal Torques (to 3100#)

Camseal Class 600#, 900#, 1700# & 3100# Torque Chart

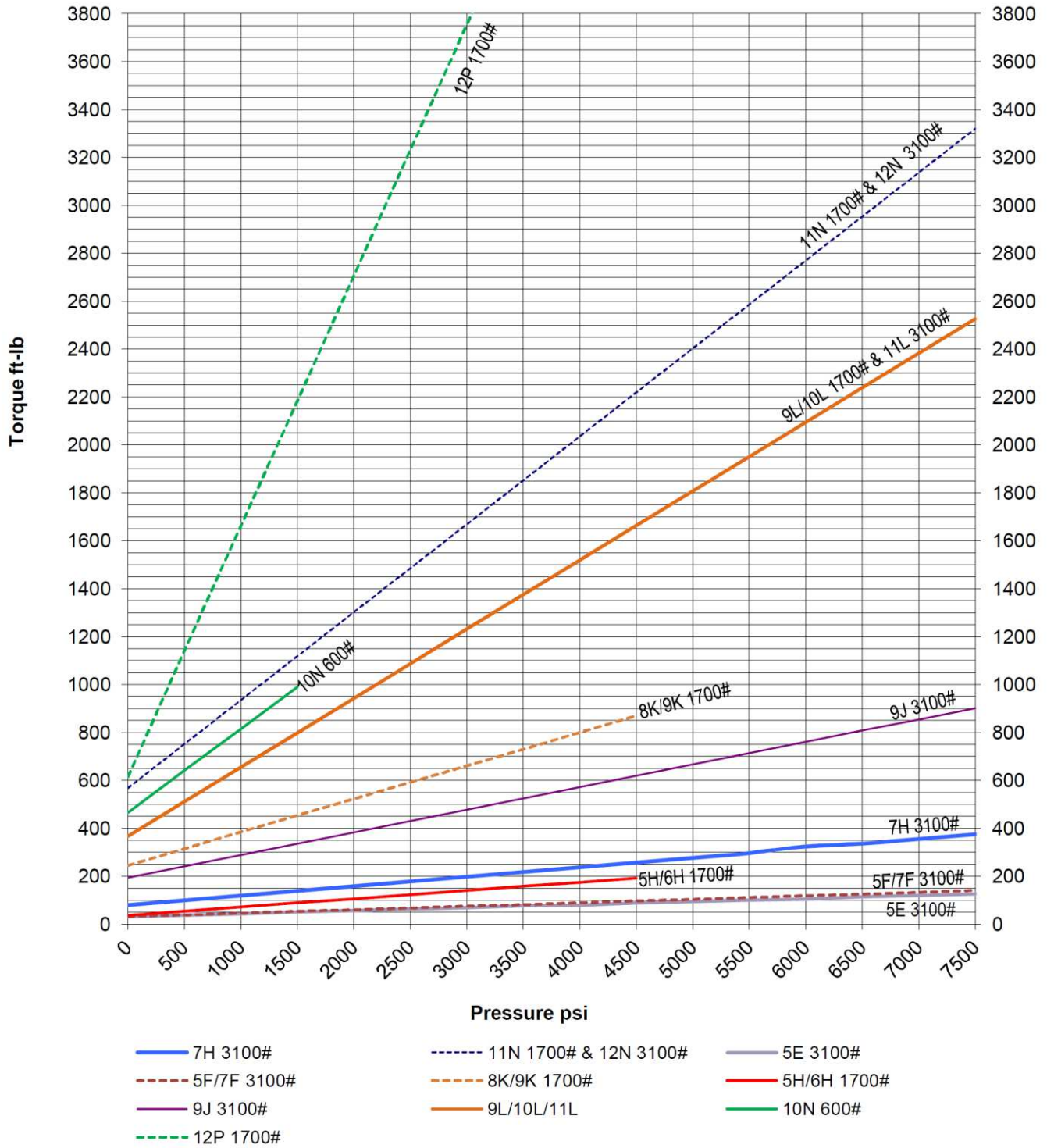
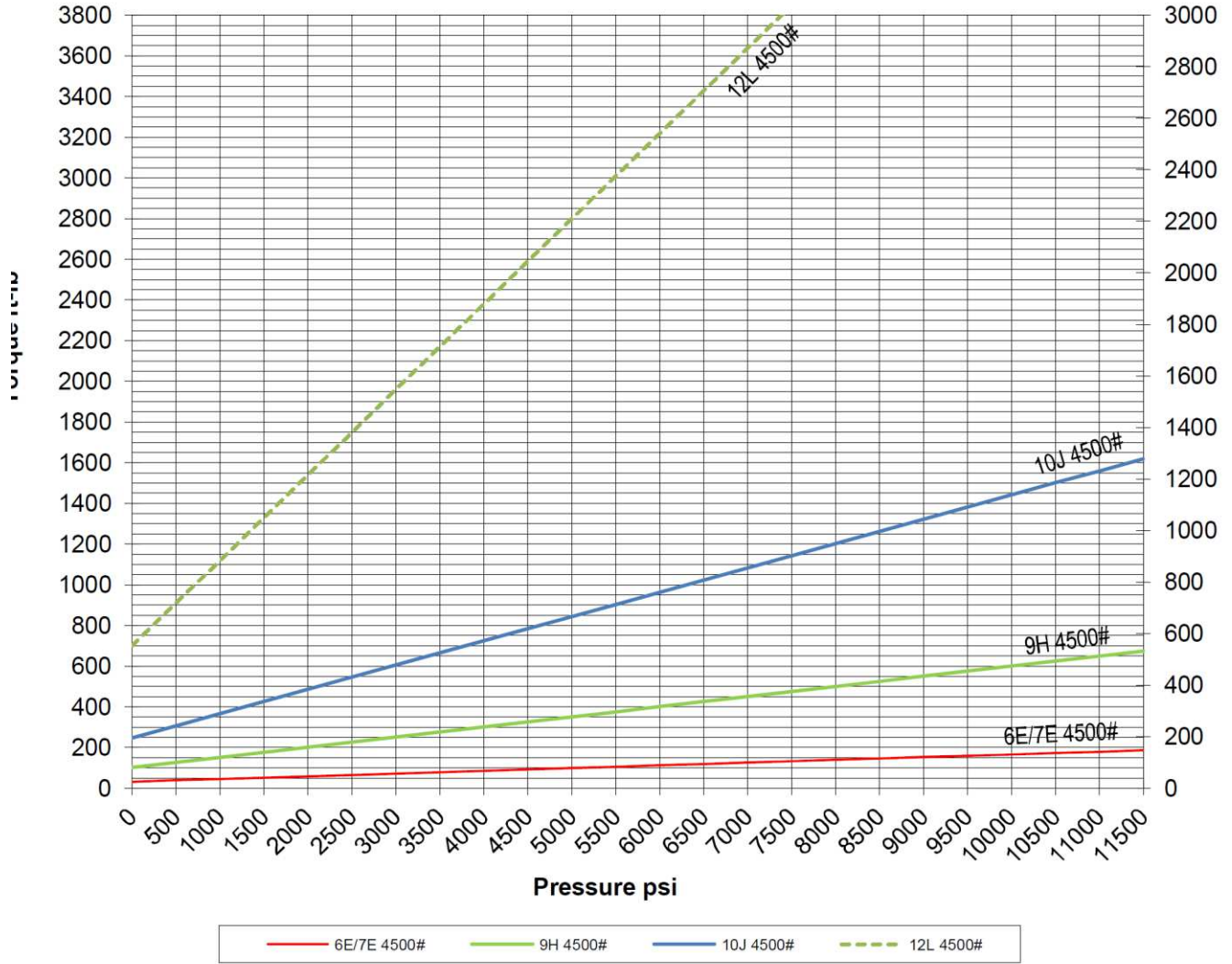

Figure 5B - Camseal Torques (4500#)

Camseal Class 4500#Torque Chart



VIII

Camseal Body/Bonnet Seal Surface Refurbishment Instructions – for Valves Equipped with Graphite/SST Laminate Seals

1. Disassemble the bonnet from body and remove the cartridge assembly as described in section IV of these instructions.
2. For valves which have been in service – whose critical body or bonnet surfaces have been corroded, worn or eroded to the point where surface refurbishment for the use of a replacement C-seal is not possible – a graphite laminate body/bonnet seal can be used in its place.
3. However; replacement **laminate seals cannot be used with a mirror-smooth or polished finish** and should have an optimum finish of 32 to 70-microinch AARH with either a concentric lay or serrated/phonographic finish.
 - 3.a. The sealing surfaces can be hand-worked using sandpaper of specific grits to achieve the desired finish.
 - 3.b. OR, using an arbor or lapping tool (C-242-H) with self-adhesive sandpaper to roughen the surfaces of the body and bonnet while applying a circular lay pattern.

Refurbishment procedure for the use of laminate seals:

4. For parts that have been in service – CLEAN all corrosion, rust and scale from the critical sealing surfaces of the body and bonnet using SCOTCH-BRITE or equivalent abrasive pads.
5. INSPECT the cleaned surfaces of the body and bonnet to ensure there are no excessive pits, cracks, chipped plating or other damage that would cause leakage across the critical seal contact face (see Figure 7 below):

Figure 7 – Inspection of the Sealing Surfaces and Acceptable Defects

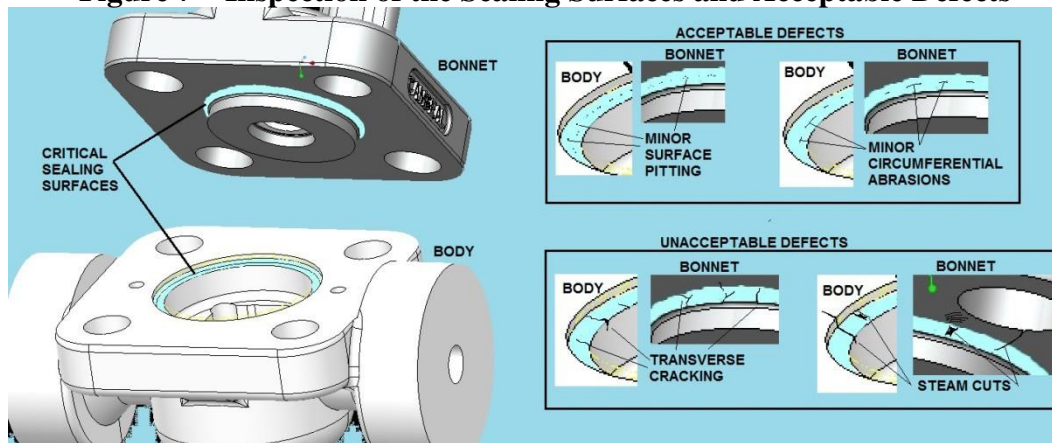

6. Increase the surface roughness of both the body and bonnet critical sealing surfaces by **SANDING** using 120-grit sandpaper – or rougher as needed – using the following methods:
 - 6.a. **BY HAND** – using moderate hand pressure, fold a piece of sandpaper sheet and form into approximate circular contour of the surface and sand in a **CONCENTRIC** fashion with a slight back-and-forth motion repeatedly around the circumference until the desired roughness is reached (See Figure 8 below).
 - 6.b. Using a **POLISHING TOOL / ARBOR** – using adhesive-backed sandpaper (Ref: Tool C-242-E-120-2.750C for 5E) attached to a polishing tool or arbor (as suggested in Figure 8), and apply the arbor to the sealing surfaces using **MODERATE PRESSURE** at **LOW RPM**, frequently brushing or blowing off surfaces until the desired roughness is achieved.

Figure 8 – Sanding methods for Laminate Seal preparation

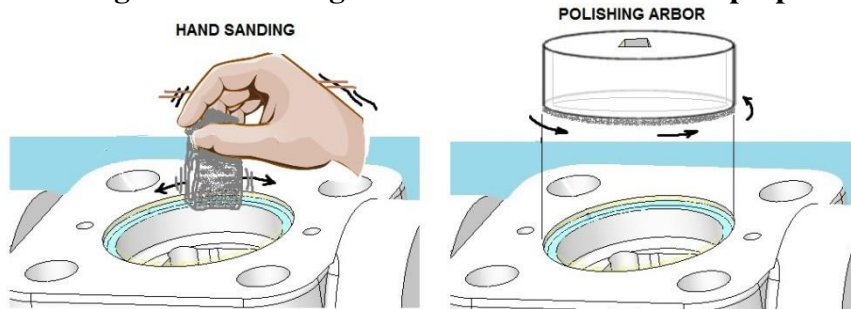

7. **CLEANLINESS** – clean surfaces with a mild degreaser and lint-free cloths to remove any grease or residue, or any loose grit from sandpaper before attempting to install the laminate seals.
8. **FINAL INSPECTION** – use a fingernail to verify that a rougher surface with a concentric lay has been created by the sanding operation. Use a roughness height comparison block, or visual comparison to verify approximate roughness height to ensure it is within specification.
9. **FINAL ASSEMBLY AND VERIFICATION** –
 - 9.a. Prior to assembly, inspect the replacement laminate seals and ensure their top and bottom surfaces have not been damaged, cut or dented during shipment or handling. Deep dents, cuts or abrasions will adversely affect sealing performance.
 - 9.b. Reassemble the valve in accordance with the procedures of Section IV. It is recommended that a **SYSTEM PROOF TEST** be performed – if a full hydrostatic test of the valve assembly is not possible – to ensure the new seal in the assembly is ready for service.

Figure 6A – Body/Bonnet C-Seal Groove Resurfacing Tool (5E shown)

C-242-SERV



C-242-H

BODY SEAL REFACING TOOL KIT LIST		DESCRIPTION	USED ON
QTY	PART NUMBER		INCLUDED PARTS BELOW
1	C-242-H	5E RESURFACING TOOL HOUSING ASSY	BODY/BONNET C-SEAL PREP ONLY
10	C-242-E-SCOTCH-2.752	PSA SCOTCH-BRITE / ADHESIVE-BACK	BONNET SIDE, LAMINATE SEAL ONLY
10	C-242-E-120-2.718C	CERAMIC 120 GRIT SAND PAPER	BONNET SIDE, LAMINATE SEAL ONLY

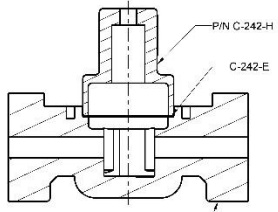

BODY 14031, 16692, 16659

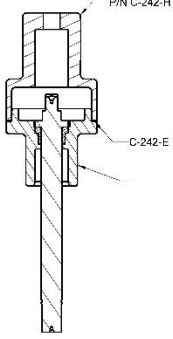

BONNET 16689, 16661

DESIGNED BY		DATE		REV		BY	
CHECKED BY		DATE		REV		BY	
DESIGNED	DATE	DESIGNED	DATE	REV	BY	REVISIONS	
VEN	1-9-20	DEBAJ				001	
DATE	DATE	C-242-SERV					
SEAL GROOVE REFACING SERVICE TOOL							
Conval INC.		SOMERS, CT.		SE	C-242-SERV		

VII

CAMSEAL LAMINATE CARTRIDGE SEAL BULLETIN

Conval introduces our upgraded Camseal Laminate Cartridge Seal Design. The high strength, laminate seal replaces the plated metal C-ring seal, improving performance and making in line servicing of the Camseal even more user friendly.

Note that Camseal bodies originally manufactured to accept a C-ring cartridge seal can be reworked per these steps to utilize a laminate cartridge seal. Camseal bodies that were originally manufactured to accept a laminate cartridge seal cannot accept a C-ring cartridge seal. Refer to Table 1 for a quick reference guide.

Camseal Body/Seat Seal Surface Refurbishment Instructions

1. The cartridge assembly will be accessible once the yoke and bonnet assembly are removed as shown in the service instructions section IV.
2. When looking downstream, turn the cam to the right of cartridge clockwise 90 degrees, at the same time turn the cam to the left of the cartridge counter-clockwise 90 degrees. This will remove the load to the seat seal. Remove the cartridge assembly components from the body. See Figure 2 showing the cams in the relaxed position.
3. Examine the body seat sealing surface.
4. For valves that had a C-seal as the mechanism to seal. Be certain to remove all of the silver plating that may have adhered to the body.
5. Use Scotch-Brite with moderate pressure in a circular motion around the port to clean the surface. The surface finish of the body was originally a 16 RMS finish with a circular lay.
6. Once the surface is clean, take a (1) inch square piece of 120 grit sandpaper and apply moderate pressure while rotating it around the port in a circular fashion. This will roughen the finish up to a 32/70 RMS finish with a circular lay. **CAUTION: Make certain no axial scratches or wire draw cuts are present in the body seal surface.**
7. For valves with a laminate seat seal, remove all the prior laminate material from the body seat surface. With moderate pressure Scotch-Brite the surface of the body sealing surface in a circular fashion around the port to

restore the 32/70 RMS circular finish. CAUTION: **Make certain no axial scratches or wire draw cuts are present in the body seal surface.**

8. Clean the surface with a mild degreaser and lint free cloths to remove any grease residue, or any loose grit from sandpaper before attempting to install the new cartridge assembly with the laminate seal.
9. Perform final visual inspection with good lighting of the surface.
10. Install the new cartridge assembly as shown in section II.

- I. The surfaces of the cartridge seat groove and the body require a 32/70 RMS finish. Previously the C-Seal required a 16 RMS finish. See Figure 1 showing the loose components of the cartridge assembly and the body.

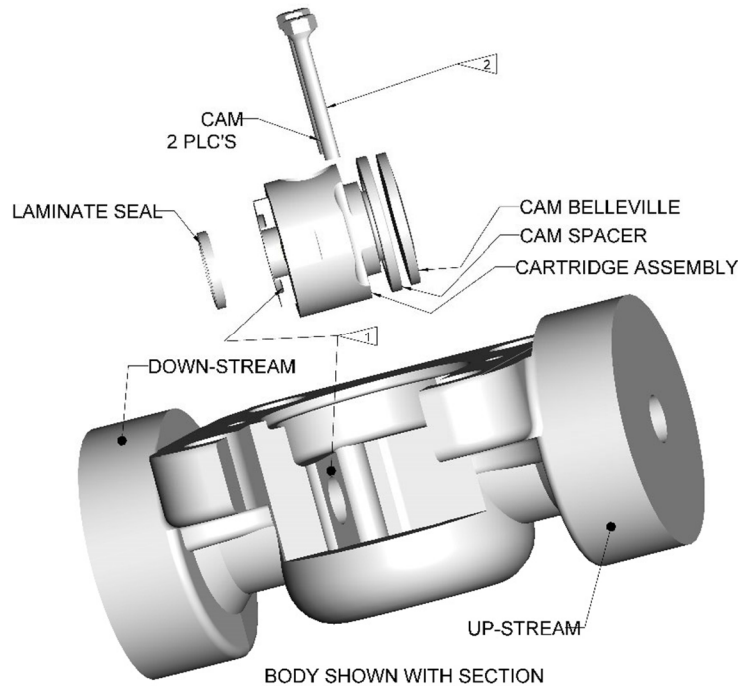

- 1- SEAT AND BODY HAS A 32-70 RMS CIRCULAR LAY FINISH FOR EASE OF REPAIR IN THE FIELD WITH THE LAMINATE SEAL
- 2- CAMS IN RELAXED POSITION FOR ASSEMBLY. CAM INSTALLED AFTER CARTRIDGE ASSEMBLY IS PROPERLY LOCATED IN THE BODY
- 3- NEW CAMS ARE REQUIRED FOR FIELD REPAIR WITH LAMINATE SEAL, CAMS USED FOR THE C-SEAL DO NOT HAVE ENOUGH CLEARANCE FOR ASSEMBLY
- 4- NEW SPARE PART CARTRIDGE ASSEMBLIES DESIGNED FOR C-SEALS NEED TO BE REWORKED FOR USE WITH THE LAMINATE SEAL DESIGN. CONSULT THE FACTORY FOR A TRADE IN CARTRIDGE ASSEMBLY

Figure 1

II. The installation of the cartridge assembly is done in (3) steps.

Step 1: Place the laminate seal into the seal groove of the Cartridge assembly. Place the TF-K Layer of the seal as shown in Figure 2 for proper orientation.

Step 2: The Cam Spacer and the Cam Belleville slide on the cartridge assembly as shown in Figure 1. Carefully slide the cartridge assembly into the body so that the laminate seal does not contact the body surface. The guides on the body wall will correctly position the cartridge assembly.

Step 3: Insert the Cams into the cartridge assembly so that the flat rests against the Cam Spacer. Slide the Cams into the cartridge assembly. See Figure 3.

CAUTION: Cams used on C-seal cartridges will not allow for proper clearance to assemble laminate seal cartridges. Different Cams are required.

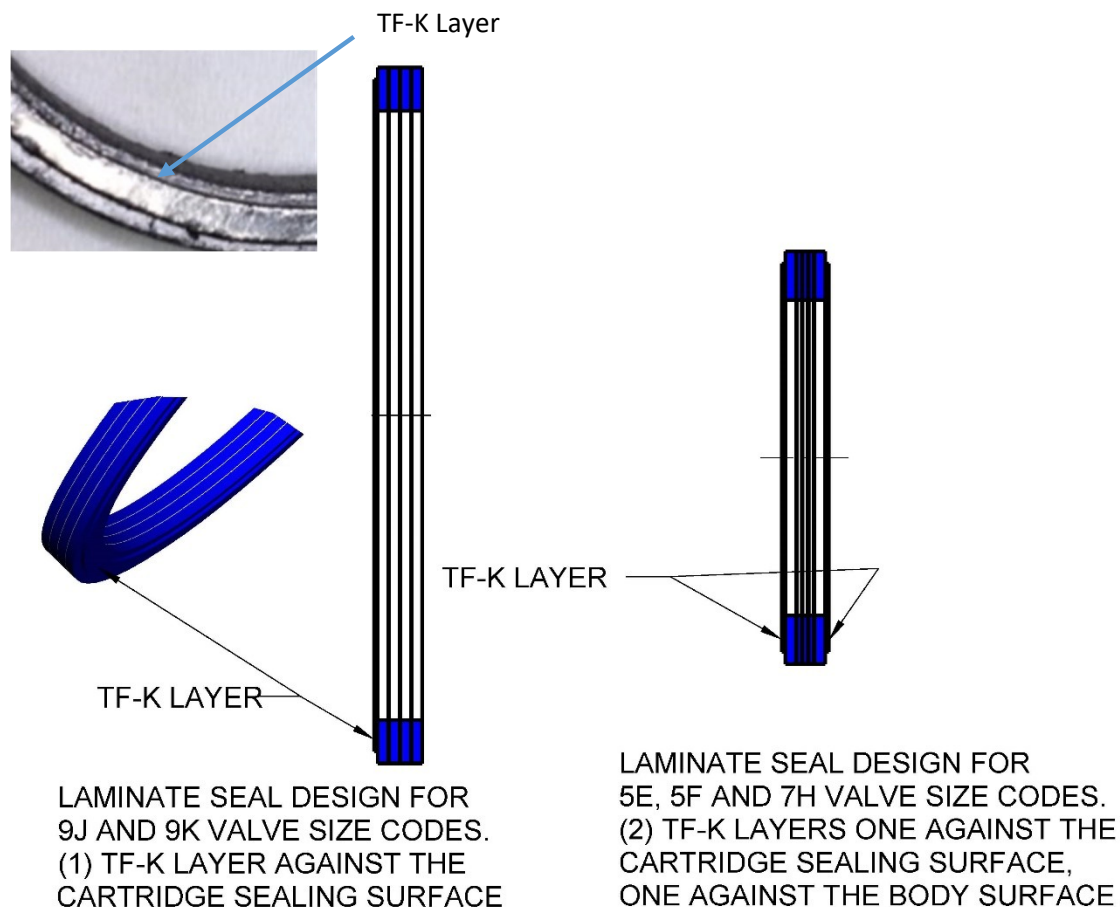

Figure 2

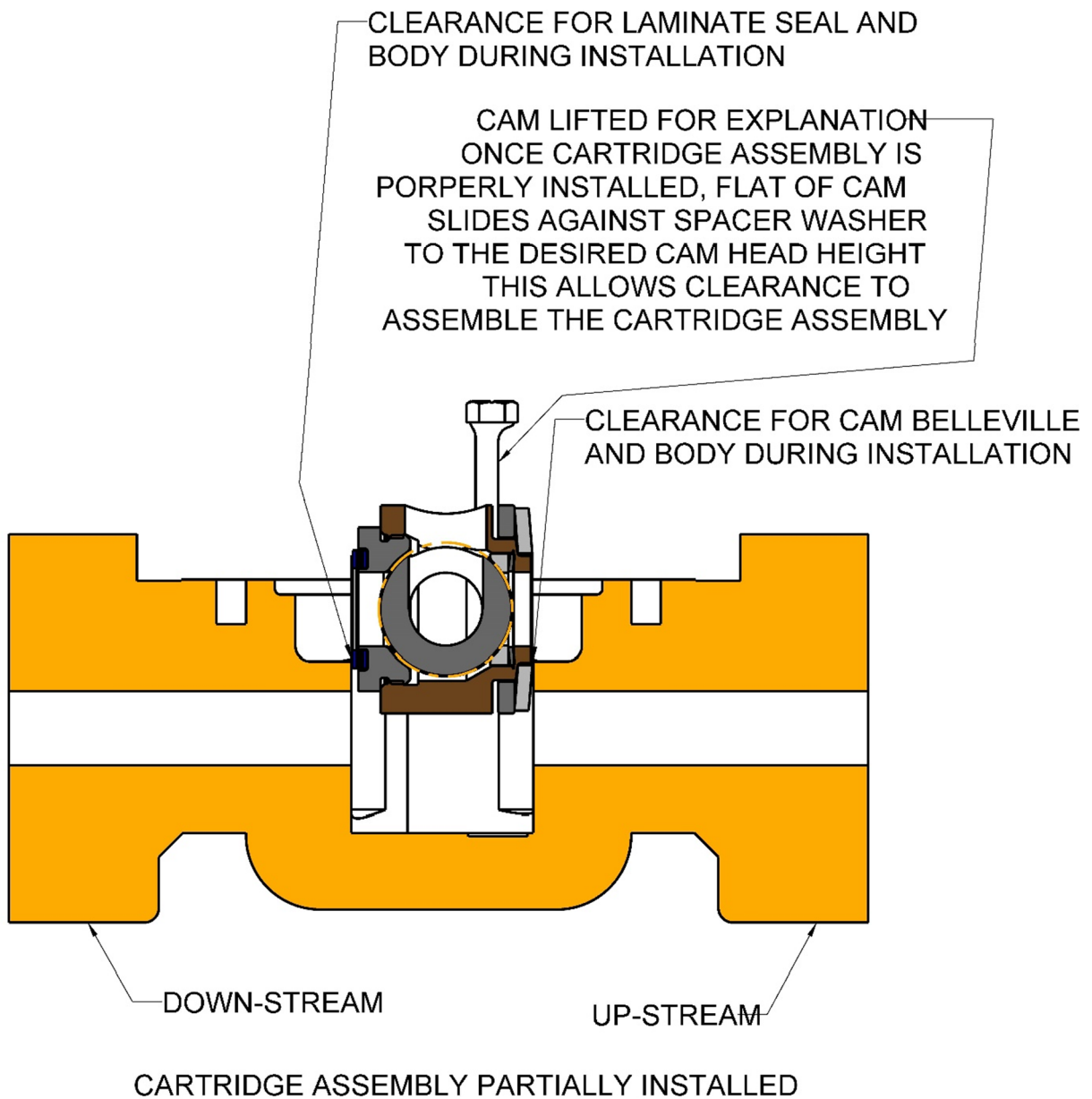

Figure 3

III Fully installed cartridge assembly (see Figure 4)

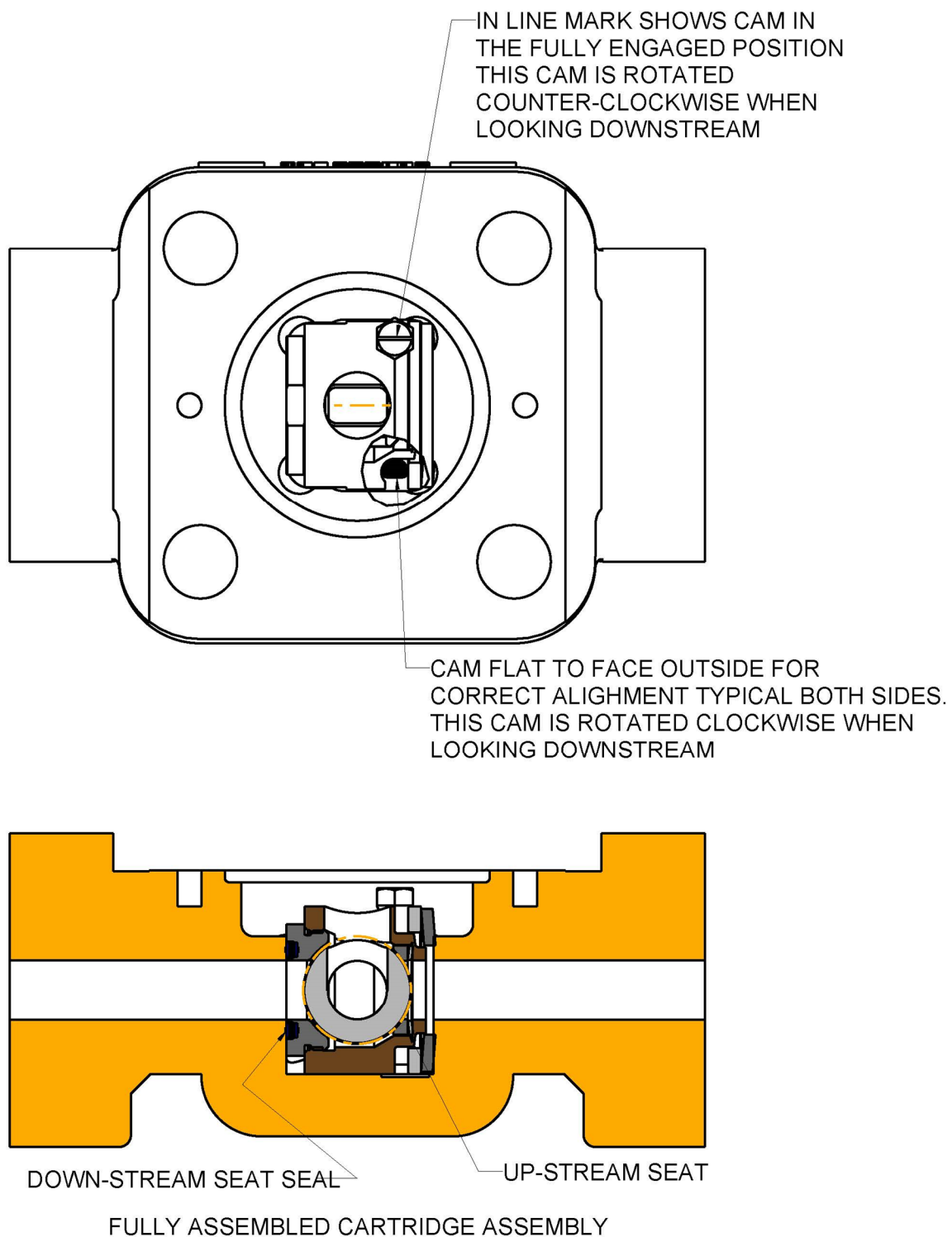

Figure 4

Table 1

Body Style (C-Ring or Laminate Cartridge Seal)	Body Will Accept Laminate Seal Design Cartridge Assembly?	Body Accept C-Ring Seal Design Cartridge Assembly?
C-Ring	Yes, surface finish rework required, new cams required	Yes, no rework required
Laminate	Yes, no rework required	No, cannot be used. Must replace with a laminate seal design cartridge assembly

Cartridge Assembly Kit Parts (C-Ring Seal Design)	Cartridge Assembly Kit Parts (Laminate Seal Design)
Cartridge Assembly	Cartridge Assembly
C-Ring Seal	Laminate Seal
Body/Bonnet Seal	Body/Bonnet Seal
	Cam (2)
	Cam Spacer
	Cam Belleville



High performance valves and accessories for the world's most *demanding* applications.

World Headquarters: 96 Phoenix Ave, Enfield, CT 06062

USA Phone (860) 749-0761 Fax (860) 763-3557

e-mail: sales@Conval.com www.Conval.com

Conval's policy is one of continuous development and improvement. Every effort is made to produce up-to-date literature but this catalog should not be regarded as an infallible guide to current specifications and does not form part of any contract. Conval reserves the right to make product improvements and changes without prior notice.

Form: CamsealServicing2021-KIT Printed in USA