

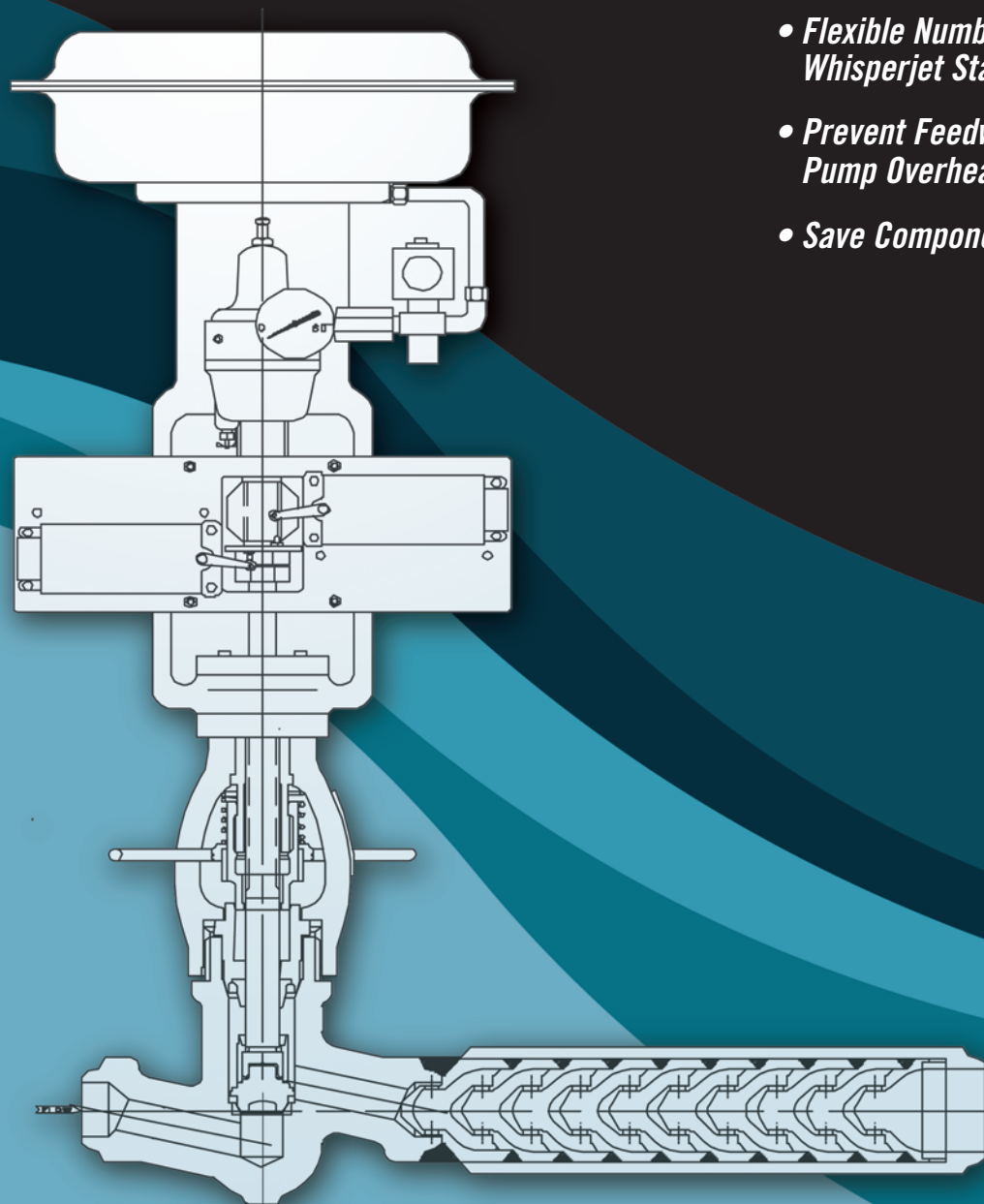

World Class Clampseal® Feedwater Pump Recirculation Bypass Valve

- *High Pressure Drop*
- *Flexible Number of Whisperjet Stages*
- *Prevent Feedwater Pump Overheating*
- *Save Component Wear*



Conval Clampseal® Recirculation Bypass Valves are designed to prevent overheating of feedwater pumps during critical low-load operating periods.

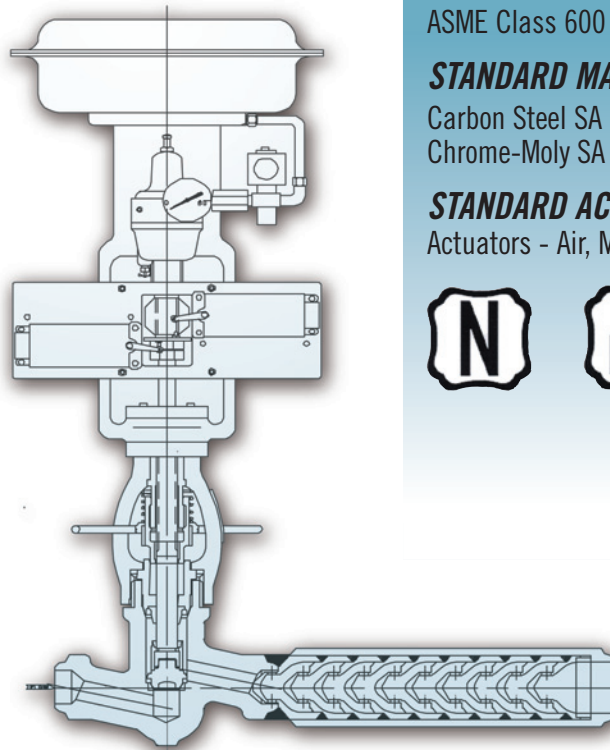
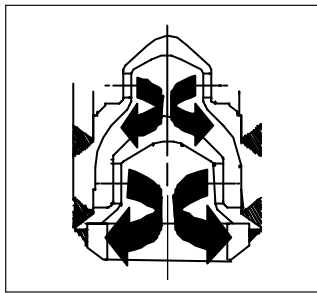

STANDARD SIZES

1/2" through 4"
Angle, Y or T-pattern
SW, BW Ends

PRESSURE RATING

ASME Class 600 through 4500

STANDARD MATERIALS

Carbon Steel SA 105
Chrome-Moly SA 182-F22, F91

STANDARD ACCESSORIES

Actuators - Air, Motor, Hydraulic, Manual



DESIGN FEATURES

High-performance Packing System

Corrosion-inhibited, high-density graphitic packing, uniform loading from the axial one-piece gland, highly polished stem and stuffing box ensure a tight seal.

Leak-proof Bonnet/Chamber

A secure, leak-proof bonnet allows rapid access to valve trim for inspection and maintenance.

Pressure Actuated Backseat

Maximum valve integrity ensures a positive internal stop for the valve stem and disc assembly while extending packing life by securely isolating the packing from line pressure when the valve is fully open.

In-Line Servicing

Conval's recirculation bypass valve is the world's most serviceable valve of its type. The topworks assembly can be replaced in minutes.

Long Device Life

With the Whisperjet, high-pressure water is discharged through a series of multi-pressure reduction stages. Each Whisperjet section has 4-6 orifices around the perimeter. The orifices discharge inwardly, which allows flow streams to impinge on each other rather than on the valve or sections themselves. This reduces the pressure in stages and prevents critical pressure drop from occurring, which serves to minimize erosion by limiting the velocity of the fluid through the valve.

Longer System Life

When Whisperjets are used in conjunction with a valve or other system components, the seat life of the valve is substantially increased. When used before a condenser or flash tank, the baffle and tank wear is greatly reduced.

Reliable

Whisperjets have been installed in power plant applications around the world for over 30 years. They are proven to be rugged and reliable in high-pressure environments.

Economical

Due to their modular design, Whisperjet-fitted Clampseal globe valves are low-cost alternatives to control valves in minimum flow feedwater pump recirculation systems.

Flexible

The number of Whisperjet stages may be varied for almost any flow requirement. Our engineering department will work with you to custom-specify Whisperjet to meet your needs.

SPECIFICATIONS

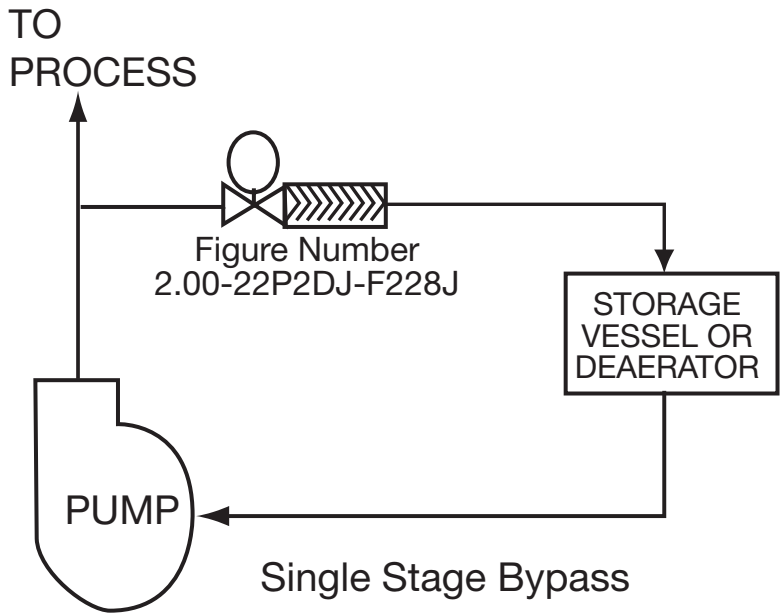

Typical Specification A

- Inlet: 2845 psi water @ 310°F
2" socket weld pipe
- Outlet: 115 psi water
- Flow: 110 gpm (60,000 #/hr)
- Solution: Conval Feedwater Pump Recirculation Bypass Valve with 11-stage Whisperjet

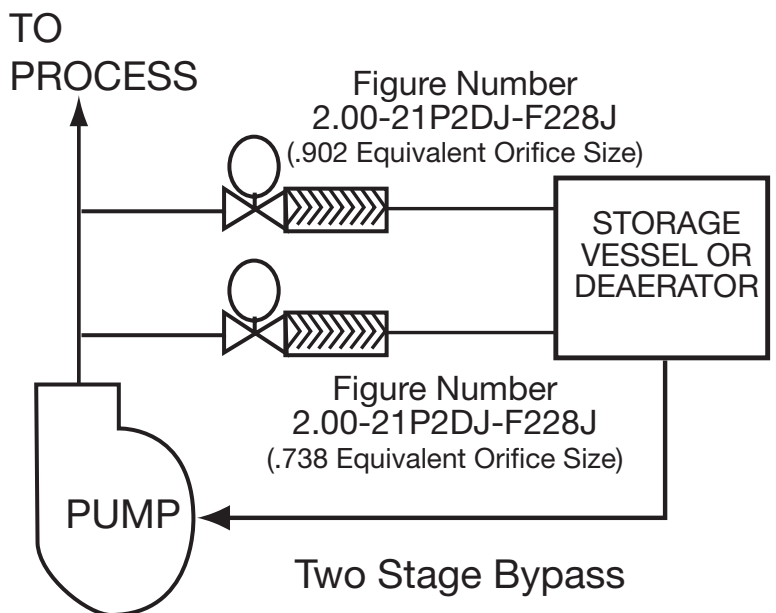

Typical Specification B

- Inlet: Valves 1 and 2 1850 psi water @ 350°F
2" socket weld pipe
- Outlet: 45 psi water
- Flow: Valve 1 160 gpm; valve 2 240 gpm
- Solution: Valves 1 & 2 Conval Feedwater Pump Recirculation Bypass Valve with 8-stage Whisperjet

The Conval Story

In 1962, Mr. Chester Siver completed designs for a revolutionary line of high-pressure, forged steel valves. Hamilton Standard (now Hamilton Sunstrand), a division of United Technologies Corporation, was asked to use their then-new Electron Beam Welding technology for joining of parts into valves for subassemblies. Hamilton Standard became intrigued with the valve as an ideal application of the Electron Beam Welding technique, and negotiated a contract for the rights to manufacture and sell the valve. Mr. Siver served as manager of the valve project.



The first CLAMPSEAL® valves were introduced to the market by Hamilton Standard in 1964. However, in the mid-1960's, growing demand for the firm's popular aerospace products forced Hamilton Standard to make the decision to abandon its industrial products projects. The rights to the CLAMPSEAL valve reverted back to Mr. Siver. Since CLAMPSEAL valves were born in Connecticut, Mr. Siver founded "Conval" (short for Connecticut Valve) in 1967. Today, the valves are still manufactured in Connecticut, a state with a longstanding reputation for technological innovation and manufacturing excellence.

Conval celebrated its 40th anniversary in 2007 with the launch of the new Camseal Ball Valve. Conval has grown into a leader in valves for the world's most demanding applications. We have a global team of experts to help to meet your most challenging needs. We invite you to contact us today.

High-pressure, high-temperature ball, bellows, bonnetless, check, gate, globe, throttling, and urea service valves for the world's most demanding applications.



1967-2007

Celebrating 40+ years of excellence!

Thank you for your business.

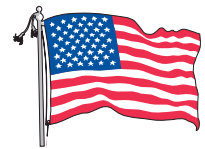

MADE IN USA

***ISO 9001 certified since
September 11, 1992***

Conval **INC.**

World Headquarters: 265 Field Road P.O. Box 1049, Somers, CT 06071-1049 USA

Phone (860) 749-0761 Fax (860) 763-3557

e-mail: sales@Conval.com www.Conval.com

Conval's policy is one of continuous development and improvement. Every effort is made to produce up-to-date literature but this catalog should not be regarded as an infallible guide to current specifications and does not form part of any contract. Conval reserves the right to make product improvements and changes without prior notice.