



## World Class Clampseal® Urea Service Valves

- *Interchangeable Modular Body Styles*
- *Pressure-actuated Backseat*
- *High-performance Packing System*
- *In-line Repairability*



**Conval Clampseal® Urea Service Valves are designed for high-pressure piping of urea reactors, strippers, and condensers.**



**STANDARD SIZES**

1/2" through 4"  
Flanged End, Hub Connector, T Pattern

**PRESSURE RATING**

ASME Class 900 to 2500

**STANDARD ACCESSORIES**

Actuators - Electric, Pneumatic, Hydraulic  
Locking Device - Open, Closed, Both  
Limit Switch - Single or Dual  
Position Indicator

**DESIGN FEATURES**

***Pressure-actuated Backseat***

The Clampseal pressure-actuated backseat provides maximum valve integrity by ensuring a positive internal stop for the valve stem and disc assembly while extending packing life by securely isolating the packing from the pressure when valve is fully open.

***Integral Gland Wrench***

The integral gland wrench makes packing adjustments simple. No tools required.

***Modular, Interchangeable Body Styles***

Three interchangeable body styles, Y, ANGLE, and T-PATTERN, use identical replacement trim parts to lessen your tool and inventory costs. Solid alloy seats provide high erosion resistance and repeatable in-line resurfacing.

***Axial-loaded Packing System***

The axial design ensures tight concentricity, which eliminates side loading of the packing and minimizes wear forces on the trim components. This feature is critical for superior valve performance.

***Compliances to Nuclear Standards***

Conval urea service valves comply to Appendix B of 10CFR50 and International Standard ISO 9001. Applications include high-pressure piping of urea reactors, strippers and condensers. Ideal for use with ammonium carbonate, nitric acid, and urea process fluids.

***Two-Year Warranty***

Conval is committed to unsurpassed quality. We are so confident of the quality of our product, that we offer a two-year warranty.

# UREA VALVE LIST OF MATERIALS

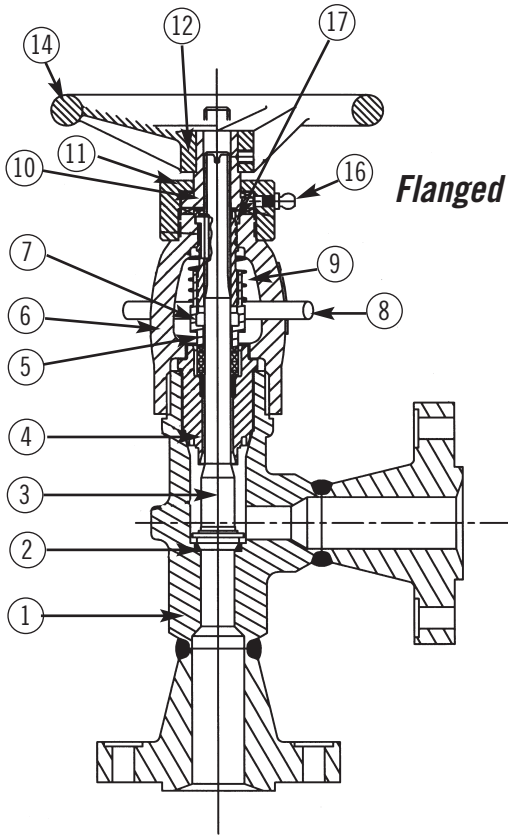

NO.	NAME	QTY	MATERIAL	SPECIFICATION
1	BODY	1	FORGED 25222 STAINLESS	UNS S31050
2	SEAT	2	FERRALIUM 255	ASME SA-479 UNS S532550
3	STEM	1	FERRALIUM 255	ASME SA-479 UNS S532550
4	BONNET	1	25222 STAINLESS STEEL	
5	PACKING	1 SET	DIE FORMED RING	HIGH DENSITY GRAPHITE
6	YOKE	1	FORGED STAINLESS STEEL	ASME SA-182 F 316
7	GLAND	1	FERRALIUM 255	ASME SA-479 UNS S532550
8	IGW	1	CAST STAINLESS	MFR. STD.
9	SPRING	1	STAINLESS	MFR. STD.
10	YOKE BUSHING	1	NITRONIC 60	ASME SA-479 UNS S521800
11	KEY	1	316 STAINLESS STEEL	MFR. STD.
12	BEARING CAP	1	316 STAINLESS STEEL	MFR. STD.
13	STEM NUT	1	NITRONIC 60	MFR. STD.
14	HANDWHEEL	1	DUCTILE IRON	ASTM A536
15	SET SCREW	1	ALLOY STEEL	MFR. STD.
16	GREASE FITTING	2	STEEL	MFR. STD.
17	BEARING ASSEMBLY	1	STEEL	ASME SB-150 UNS C64200
18	ID PLATE	1	STAINLESS	MFR. STD.
19	CLAMP BOLT	1	STAINLESS	MFR. STD.

13, 15, 18 & 19 (NOT SHOWN IN VIEWS)

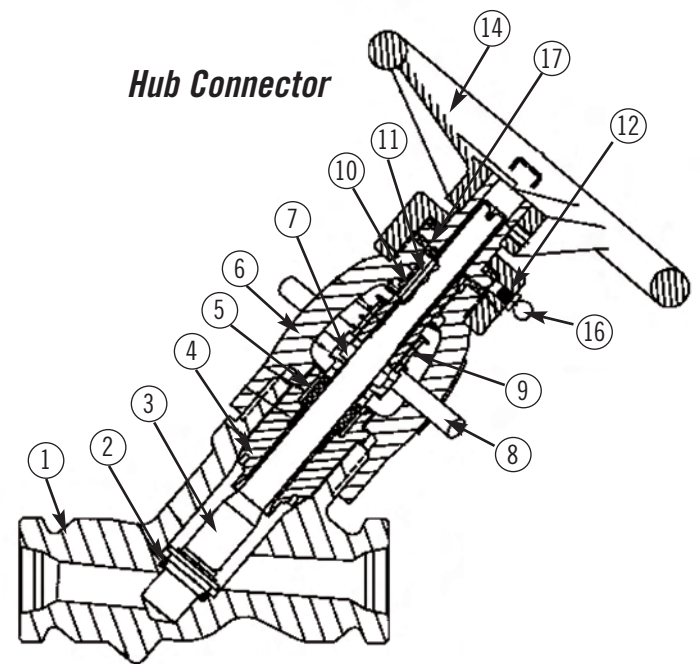
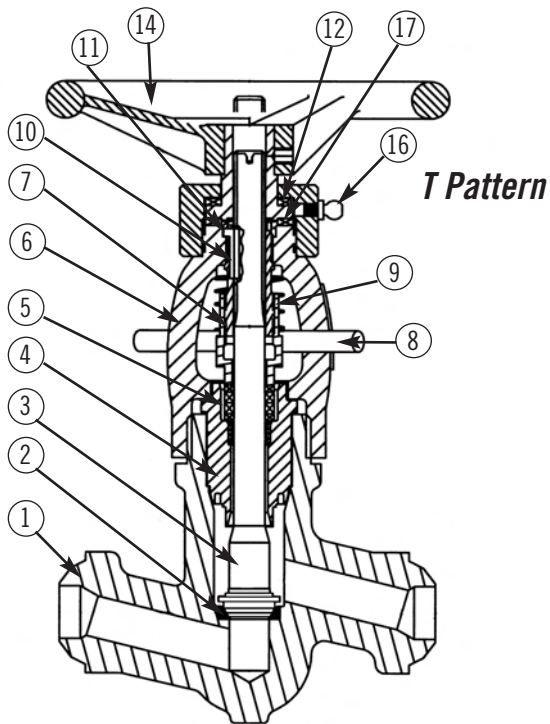

## The Conval Story

In 1962, Mr. Chester Siver completed designs for a revolutionary line of high-pressure, forged steel valves. Hamilton Standard (now Hamilton Sunstrand), a division of United Technologies Corporation, was asked to use their then-new Electron Beam Welding technology for joining of parts into valves for subassemblies. Hamilton Standard became intrigued with the valve as an ideal application of the Electron Beam Welding technique, and negotiated a contract for the rights to manufacture and sell the valve. Mr. Siver served as manager of the valve project.



The first CLAMPSEAL® valves were introduced to the market by Hamilton Standard in 1964. However, in the mid-1960's, growing demand for the firm's popular aerospace products forced Hamilton Standard to make the decision to abandon its industrial products projects. The rights to the CLAMPSEAL valve reverted back to Mr. Siver. Since CLAMPSEAL valves were born in Connecticut, Mr. Siver founded "Conval" (short for Connecticut Valve) in 1967. Today, the valves are still manufactured in Connecticut, a state with a longstanding reputation for technological innovation and manufacturing excellence.

Conval is celebrating its 40th anniversary in 2007 with the launch of the new Camseal Ball Valve. Conval has grown into a leader in valves for the world's most demanding applications. We have a global team of experts to help to meet your most challenging needs. We invite you to contact us today.

**High-pressure, high-temperature ball, bellows, bonnetless, check, gate, globe, throttling, and urea service valves for the world's most demanding applications.**



**1967-2007**

***Celebrating 40+ years of excellence!***

***Thank you for your business.***



MADE IN USA

***ISO 9001 certified since  
September 11, 1992***

***Conval*** **INC.**

World Headquarters: 265 Field Road P.O. Box 1049, Somers, CT 06071-1049 USA

Phone (860) 749-0761 Fax (860) 763-3557

e-mail: [sales@Conval.com](mailto:sales@Conval.com) [www.Conval.com](http://www.Conval.com)

Conval's policy is one of continuous development and improvement. Every effort is made to produce up-to-date literature but this catalog should not be regarded as an infallible guide to current specifications and does not form part of any contract. Conval reserves the right to make product improvements and changes without prior notice.